

# SPECIFICATIONS

## S E R I E S 7 0 0 0 W T WEIGHTED BACK DRAFT DAMPER

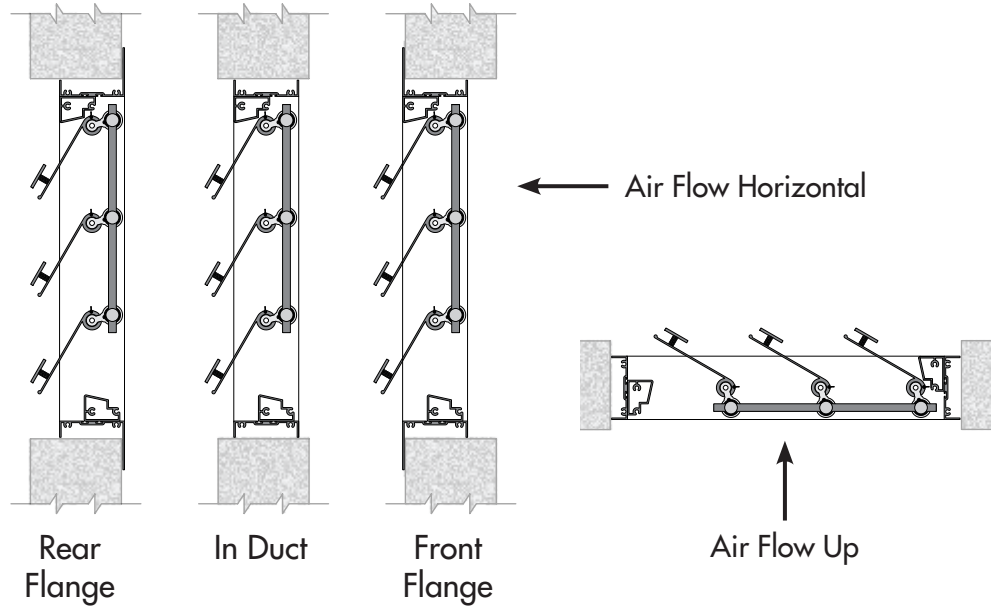
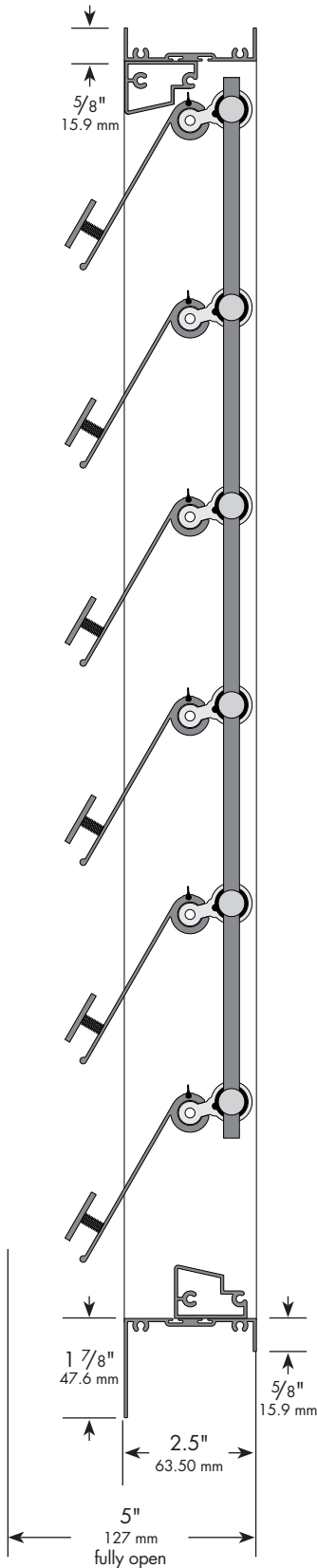

- Extruded aluminum (6063T5) weighted back draft damper frame is not less than .060" (1.52mm) in thickness. Frame is 2.5" (63.5mm) deep.
- Blades are extruded aluminum (6063T5) profiles and not less than .060" (1.52mm) in thickness.
- Each blade is manufactured with a mounting hole to receive a front-mounted mechanical weight. Weights are supplied, so that the required resistance to the opening of the blade against air flow can be achieved.  
(To facilitate opening of blades, refer to the Series 7000 CW Specifications. The Series 7000 CW is an adjustable, counterweighted back draft damper designed to allow opening at lower pressures and air flow velocities.)
- Blade and side seals are extruded silicone. Seals are secured in integral slots within the aluminum extrusions.
- Bearing system is composed of Celcon bearings rotating on 1/2" (12.7mm) aluminum pivot points.
- Linkage system consists of hard alloy aluminum (6005T6) crank arms fastened to aluminum pivot rods and doubly secured within channel running along top of blade. Large diameter 1 1/32" (8.73mm) hard alloy aluminum (6065-T6C) linkage rod connects the crank arms by means of a zinc-plated steel trunnion.
- Cup-point trunnion screw allows for a penetrating grip of the linkage rod.  
(Cup-point trunnion set screw creates a compression hard spot where it secures to the linkage rod.)
- Trunnions are zinc-plated to provide a hard, smooth and long-lasting rotating surface.
- Weighted back draft dampers are designed for operation in temperatures ranging between -72°F (-58°C) and 212°F (100°C).
- Air leakage through a 24" x 24" (610mm x 610mm) weighted back draft damper does not exceed 17.5 cfm/ft.<sup>2</sup> (88.6 l/s/m<sup>2</sup>) against 1" (.25 kPa) w.g. differential static pressure at standard air.
- Weighted back draft dampers are made to size required.  
Minimum section size: 6" wide x 6" high (153mm x 153mm)  
Maximum section size: 36" wide x 48.625" high (914mm x 1235mm)  
Weighted back draft dampers with dimensions greater than maximum section size will be manufactured in multiple sections. Multiple sections are not interlinked or connected. To install, each section must be individually fastened to a structural frame prepared on site.
- Available in three mounting types: "Rear Flange", "In Duct", or "Front Flange".

### Note:

- Suitable for operation in breathable air environments within stated temperature range.
- For air flow down mounting, specify TAMCO Series 7000 CW Counterweighted Back Draft Damper.
- 1/4" is deducted from the opening dimensions to allow for clearance on mounting types Rear Flange, In Duct, Front Flange.
- 1/4" clearance deducted from Rear Flange and Front Flange mounting types affects effective flange.

### For additional information, refer to:

- Series 7000 Specification Sheet
- Series 7000 CW Specification Sheet

# PERFORMANCE DATA

## S E R I E S 7 0 0 0 W T WEIGHTED BACK DRAFT DAMPER

DAMPER WIDTH	Leakage at 1" w.g.
	cfm / sq. ft.
36" (914mm)	15.0
24" (610mm)	17.5
12" (305mm)	25.0

### Series 7000 WT Test Data:

All tests were conducted on a 24" x 24" (610mm x 610mm) rear flange mount type weighted back draft damper. The data represent the performance of the stated size only and cannot be transferred directly to other sizes. This data is meant only as an indicator of the pressures and velocities needed for all the sizes available.

### Static Pressure and Face Velocity to Open Damper:

Weights are fully adjustable so that the required resistance to the opening of the blade against air flow can be achieved.

### PRESSURE DROP

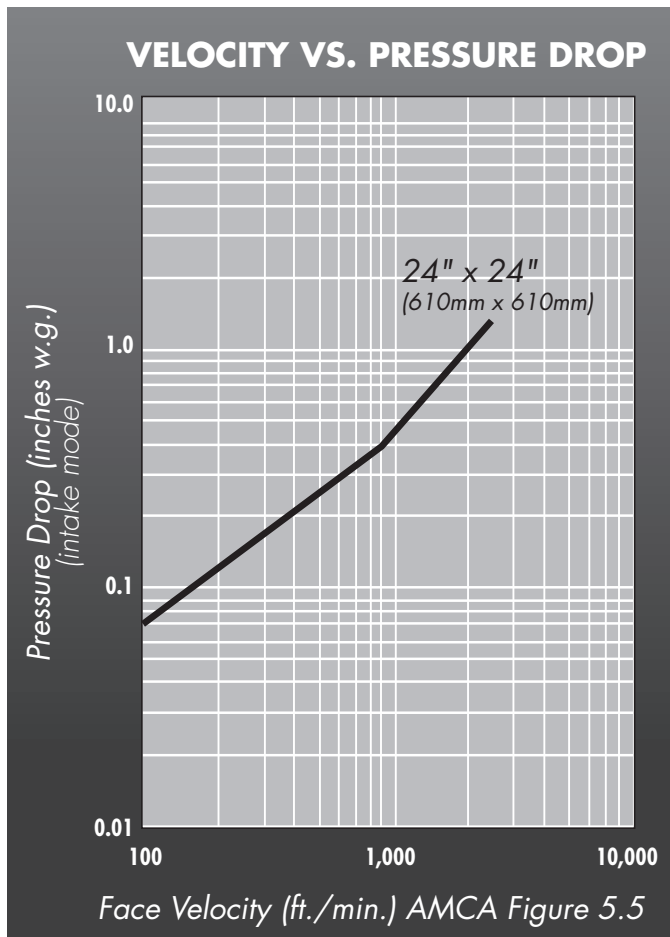

Air velocity in feet and meters per minute through face area.  
Tested per AMCA Standard 500, Figure 5.5, duct work upstream and downstream.

### BLADE LIMITATIONS

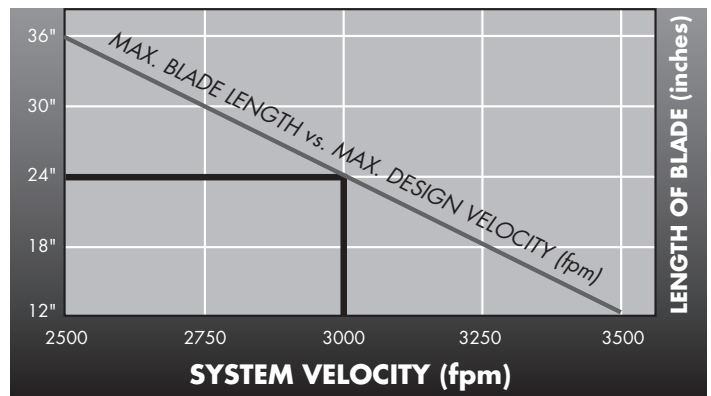
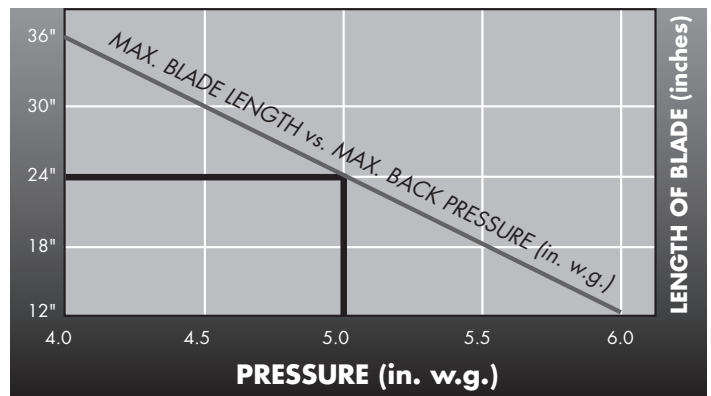

Series 7000 WT Weighted Back Draft Dampers that exceed the maximum design pressure or velocity due to blade length may be used by reducing the width of the back draft damper section(s) and increasing the number of sections per damper to maintain a blade length compatible with the stated system pressure or velocity.

Example: 1 section Series 7000 WT Weighted Back Draft Damper of 36" w x 36" h @ 3000 fpm would need to be built in 2 sections of 18" w x 36" h.